

**NON DOMESTIC (COMMERCIAL)
ENERGY ASSESSMENT**

LEVEL 3 - QUALIFICATION

Awarded by

City & Guilds



Level 3 Non Domestic Energy Assessment Training Programme

Background

There is now a legal requirement for an Energy Performance Certificate to be in place in advance of the sale or rent of all qualifying properties.

An Energy Performance Certificate (EPC) gives a potential buyer or tenant specific information about the space and water heating costs and level of carbon emissions for the property that they are interested in buying or renting. Where appropriate it also provides recommendations to reduce costs and lower emissions.

EPCs can only be produced by suitably qualified Energy Assessors.

Pyramid Associates Ltd provides a training and assessment programme for the Level 3 Non Domestic Energy Assessor Qualification. This National Framework Qualification programme has been developed to meet the National Occupational Standards for Level 3 Non Domestic Energy Assessors set by Asset Skills and is awarded by City and Guilds.

On qualification candidates will be eligible to join an approved Accreditation Scheme and then undertake surveys and produce Energy Performance Certificates for qualifying properties that come onto the market.

Study Materials

Good quality printed materials are an important medium for studying. Not only do we provide excellent print based study materials and supplementary reading books, the programme also includes a copy of the latest Energy Performance Certificate generating software; staged self-tests, sample City and Guilds examination software (to help you to navigate through the on-line exam before you actually sit it) sample exam questions, example property scenarios and site notes.

Assessment

We use a variety of assessment methods to test your knowledge and understanding of the subject matter. For instance, in each of the two core units, part is assessed by a multiple-choice on-line exam and part is assessed purely by written assignments submitted by you to your allocated tutor for marking. Full details of the assignments will be discussed during the training programme.

The Study Programme

Depending on your background the study programme will be between 3 and 6 days:-

- You will need 2 days training to understand the EPC generating software
- You may need further training to cover any or all of the topics of lighting, HVAC and building construction
- You will need a further day if you choose to undertake an accompanied survey

There are two exams for this qualification each of up to 45 minutes duration. The rest of the time will be spent completing your assignment portfolio and preparing for the exams.

PLEASE NOTE - YOU WILL NEED A LAPTOP COMPUTER WITH WINDOWS XP OR VISTA AND OFFICE 2003/3 OR 2007 INSTALLED IN ORDER TO COMPLETE THIS COURSE

Completing the programme

1. Complete and return the course booking form with your deposit and CV
2. We will assess your application and agree an appropriate training programme with you
3. We will send you joining details and an invoice for any agreed additional training
4. Submit any additional payment
5. Attend the training days
6. Submit completed assignments via post and get feedback via email
7. After our tutors have marked your work, we will contact you to arrange the exams
8. Sit the exams (your results will be available immediately)
9. Once you have passed the exams and your course work has been assessed and passed, your City and Guilds Certificate will be issued and you will be qualified to produce commercial EPCs to Level 3

Definition

This qualification is essential to gain a licence to practice as a Non-Domestic (Commercial) Energy Assessor to Level 3. Level 3 is concerned with 'Basic' buildings; these are buildings that have:-

- Simple HVAC (Heating, Ventilation and Air Conditioning systems)
- Heating system with less than 100kW output
- Simple natural ventilation
- Air conditioning no higher than 12kW output

Format

There are two units in this qualification:

- **005/007** Prepare to carry-out non-domestic energy assessments for buildings

Learning outcomes

- Explain characteristics of non-domestic buildings for inspection
- Outline the legislation and regulatory framework governing professional energy assessment practice
- Carry out pre-inspection investigation on non-domestic buildings
- Produce contracts for non-domestic energy assessments
- Evaluate safe systems of work
- Outline professional practice requirements for non-domestic energy assessors

- **006/008** Produce non-domestic energy assessments for basic buildings

Learning outcomes

- Carry out non-domestic energy assessments
- Use the Simplified Building Energy Model (SBEM) calculation tool to produce non-domestic energy assessments
- Produce recommendations to improve energy efficiency of basic buildings

Accreditation

On successful completion of the course candidates are eligible to register with one of the various accredited DEA schemes. This will allow candidates to work as a registered Non-Domestic Energy Assessor and undertake non-domestic EPCs on a commercial basis.

Eligibility

To gain a place with us you do not need to have undertaken any specific prior learning. However, in order to complete this City and Guilds qualification delegates will need to possess a degree of computer literacy; including basic word processing, use of email and accessing and searching the internet. You will need access to the internet with use of a valid email address (to receive feedback and to discuss your progress with you tutor). You must be able to climb a 3m high ladder to gain access to view elevated areas (to assess insulation levels). Once qualified, you will need to undergo a basic criminal record bureau check (CRB check) to verify your suitability to work in occupied or vacant dwellings when undertaking surveys.

Programme Fee

The full fee for the Level 3 Non-Domestic Energy Assessor programme is £900.00 plus VAT. This includes the training software, all course materials, assessment of assignments, one entry into each of the final exams and issue of the Diploma on successful completion of the course. There are no hidden extras, however exam re-sits are charged at the rate of £100.00 each plus VAT.

Certificate Award

Pyramid Associates Limited is a 'self-certifying' centre; this means that we authorise the issue of certificates from City & Guilds once we deem a candidate to be competent to undertake the Level 3 Non-Domestic Energy Assessor role.

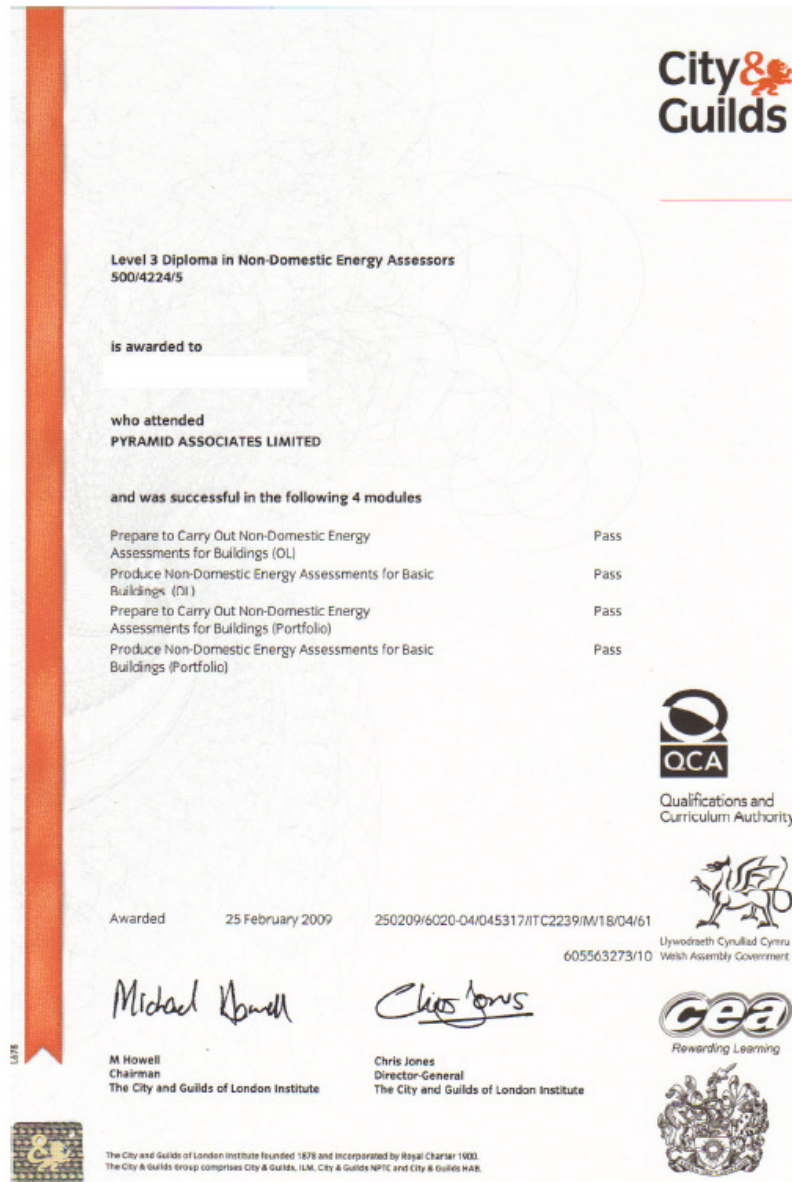

Joining the study programme

To join the study programme please complete and return the attached Booking Form with your payment to the address provided. You can apply at anytime.

The route to your Qualification

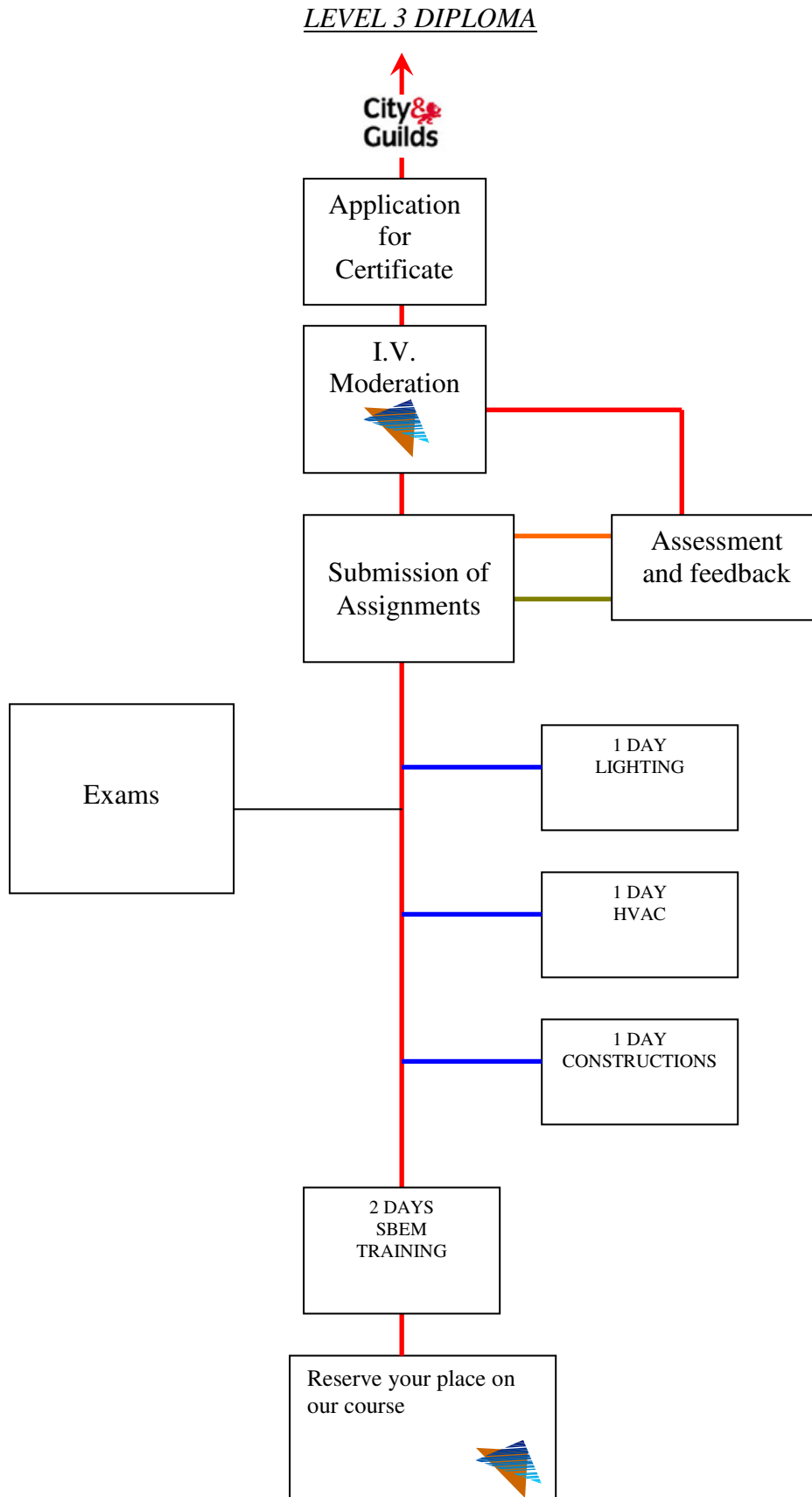



Level 3 Non-Domestic Energy Assessor Programme Booking

Form

To reserve your place on the Level 3 Diploma in Non-Domestic Energy Assessment learning programme, please complete this form and return it with your payment by post to the address shown below (or by fax to 08717 150 202 if paying by card).

Study Mode: Classroom

Title: Mr/Mrs/Miss/Ms Other (please state) _____ **Date of Application:** _____

Name: (as it will appear on any certificate awarded):

Full postal address: (including post code):

Contact telephone number:

Email address:

Date of birth: ____/____/____ **Gender:** Male / Female (please circle)

If a VAT receipt required please give name and address for VAT receipt:

Programme Fee is £900.00 plus VAT @17.5% = £1057.50

Please make cheques payable to Pyramid Associates Limited

Please return this form with your payment to:

**Level 3 NDEA Learning Programme
Pyramid Associates Limited, 16 Harris Close, Crewe, CW1 4TQ**

Fax Number 08717 150 202 *FOR CARD PAYMENTS ONLY*

Amount to be debited: _____
Type of card: VISA / MasterCard / Other (please state): _____
Name on Card: _____
Card No: _____
Expiry Date: _____ Issue No / Security Code: _____

Terms and Conditions of Booking

- Enrolment:** There are no formal entry requirements for the course. However, in order to complete this City and Guilds qualification candidates will need to possess a degree of computer literacy. Candidate enrolment is accepted on the understanding that they are able to use a computer and access and search the internet unaided. If this is not the case it is the candidates' responsibility to make this fact known to Pyramid Associates Limited in advance of the course start date so that an assessment of the candidates' suitability to complete the course can be made. Failure to disclose such information may result in the candidates' inability to complete the course, in which case no refund of any monies paid shall be made.
- Cancellation:** Once a booking has been received Withdrawal terms apply. Please see below. Pyramid Associates Limited reserves the right to reschedule the course should it be necessary. Should Pyramid Associates Limited cancel the course then an alternative date will be offered or a full refund will be made.
- Substitution:** There will be no charge if a substitute person wishes to replace the original candidate before the course begins. Please inform Pyramid Associates Limited in writing of any change to the original booking.
- Withdrawal:** If a candidate withdraws from the course whilst it is in progress no refund of any monies paid will be made.
- Refunds:** In the event that Pyramid Associates Limited cancels the course a full refund will be made. Under no circumstances will Pyramid Associates Limited be liable to refund any amount in excess of the agreed fee for the training course in question. This applies in particular (but is not limited) to any travelling, subsistence or consequential expenses incurred by candidates.
- Payment:** A candidates' continued inclusion on the course is dependant on payment being received in full prior to the first day of training. All cheques should be made payable to Pyramid Associates Limited. We accept payment via all major credit and debit cards.
- Conduct:** Candidates are expected to act reasonably throughout the training. Pyramid Associates and /or their Training Provider may remove a candidate from a course, where, in the opinion of the trainer, which shall be final, the candidate is behaving unreasonably.
- Complaints:** In the unlikely event that a candidate has reason to complain about the course materials, assessment, feedback and the like, the matter must be brought to the attention of the course tutor in the first instance. The course tutor has authority to settle such matters as deemed appropriate, but always in accordance with the Complaints Procedure as laid down by Pyramid Associates Limited. Should the nature of the complaint be such that the course tutor is unable to reach agreement with the complainer, the matter will be referred to the Internal Verifier.
- Health and Safety:** All parties involved in the training course shall comply at all times with the appropriate health and safety legislation and codes of practice.
- Warranty:** Pyramid Associates Limited warrants that in carrying out the learning programme it has and will exercise all reasonable skill and care to be expected of a professional, experienced in such work.
- Insurance:** In no event shall Pyramid Associates Limited be liable for (whether direct or indirect) any loss, damage or injury to any person or property however suffered whilst undertaking this course.